

THULE®

SWEDEN

- GB Fitting instructions
- D Montageanleitung
- F Instructions de montage
- NL Montage-instructies
- I Istruzioni per il montaggio
- E Instrucciones de montaje
- PT Instruções de Montagem
- S Monteringsanvisning
- FIN Asennusohje
- EST Paigaldusjuhend
- LAT Stiprināšanas instrukcija
- LIT Pritvirtinimo instrukcijos
- PL Instrukcja montażu
- RU Инструкции по установке
- CZ Návod na montáž
- SK Návod na montáž
- SLO Navodila za pritrjevanje
- HR Uputa za sastavljanje
- HU A felszerelés módja
- GR Οδηγίες συναρμολόγησης
- TR Montaj talimatları
- 中文 安装说明
- 日本語 取扱(取付)説明書
- 한국어 장착 지침
- ไทย คำแนะนำการติดตั้ง

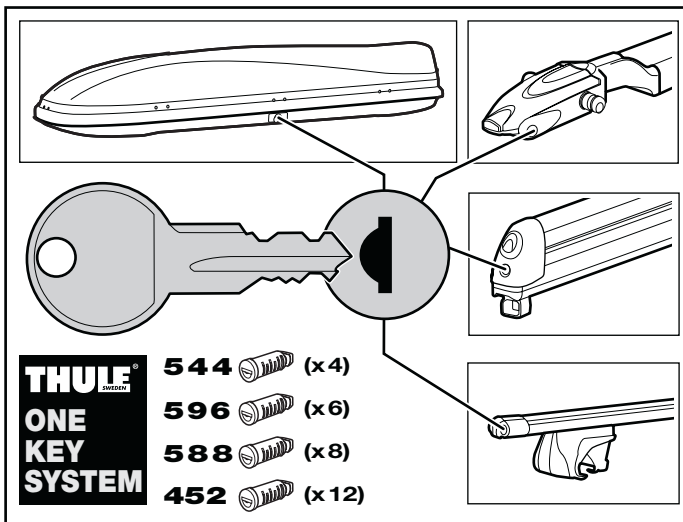
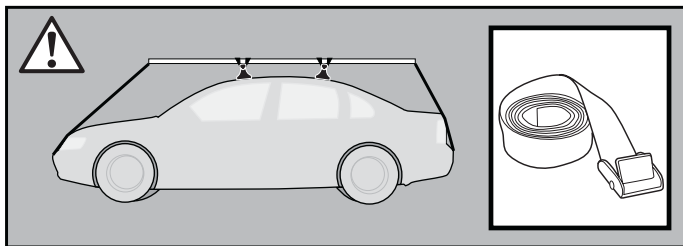
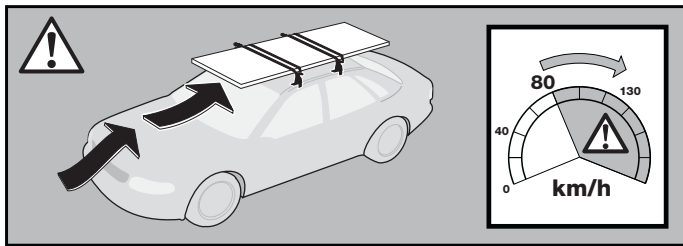
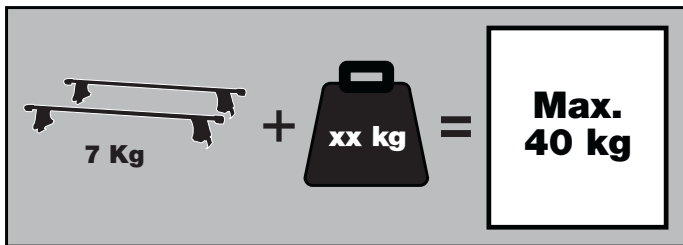

MERCEDES CLC, 2-dr Coupé, 08-

RAPID SYSTEM

Kit 1504



Follow me...

THULE®

SWEDEN

Box 69, 330 33 Hillerstorp, SWEDEN
www.thule.com

848•A/501-1504

THULE

GB Security regulations
D Sicherheits-Vorschriften
F Instructions importantes
NL Veiligheidsvoorschriften
I Norme di sicurezza
E Reglas de seguridad
PT Normas de segurança
S Säkerhetsföreskrifter
FIN Turvallisuusohjeet
EST Ohutusjuhised
LAT Drošības noteikumi
LIT Saugumo taisyklės
PL Wykazanie bezpieczeństwa
RU Инструкции по безопасности
CZ Pokyny na montáž
SK Bezpečnostné predpisy
SLO Varnostni predstvi
HR Pravila sigurnosti
HU Biztonsági előírások
GR Κοινωνικοί Αποφασισμοί
TR Güvenlik kuralları
中文 安全规范
泰文 安全规范
ไทย ระวังภัยที่เกี่ยวกับความปลอดภัย

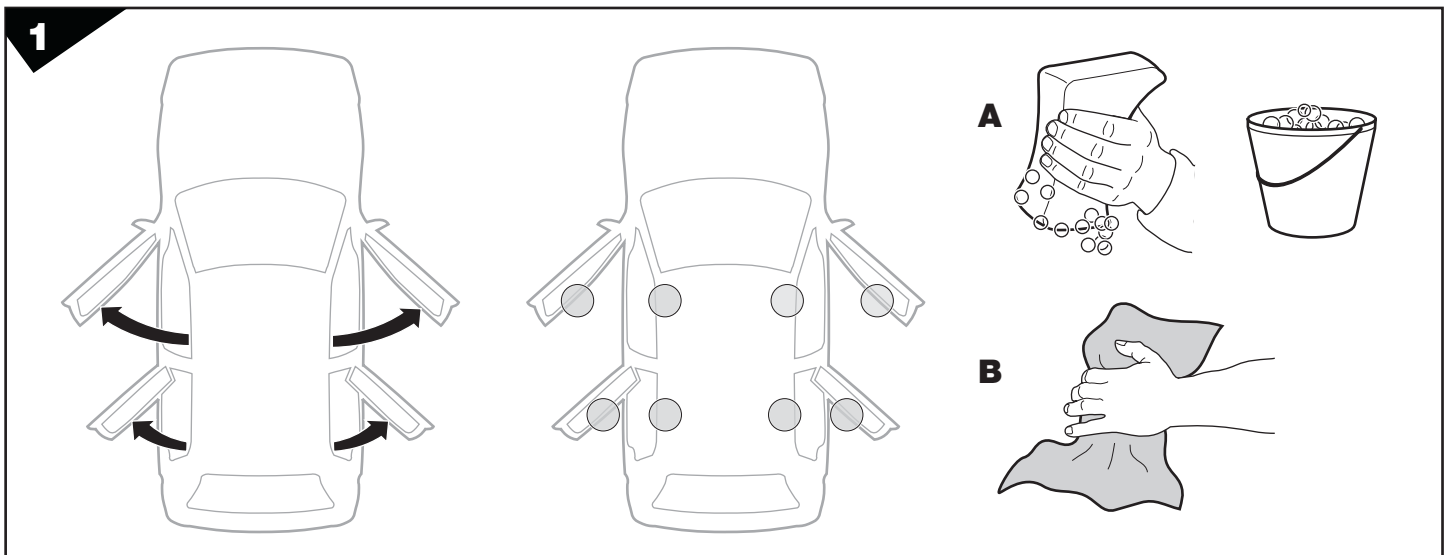
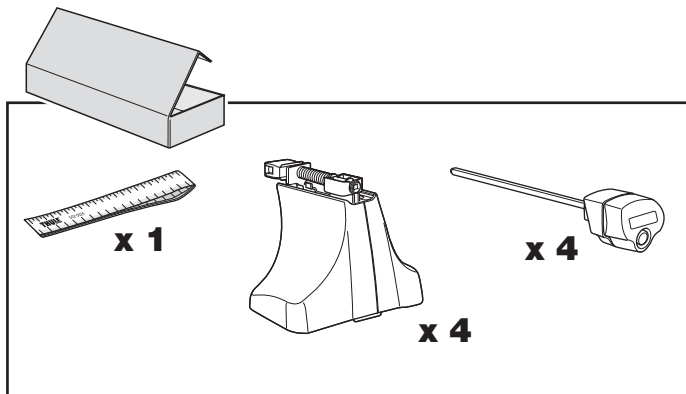
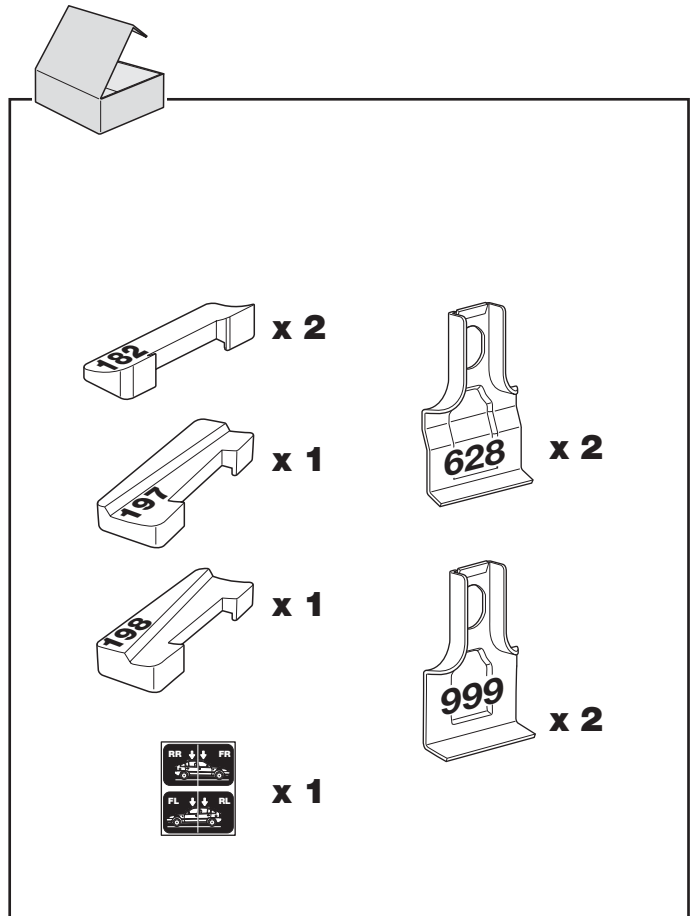
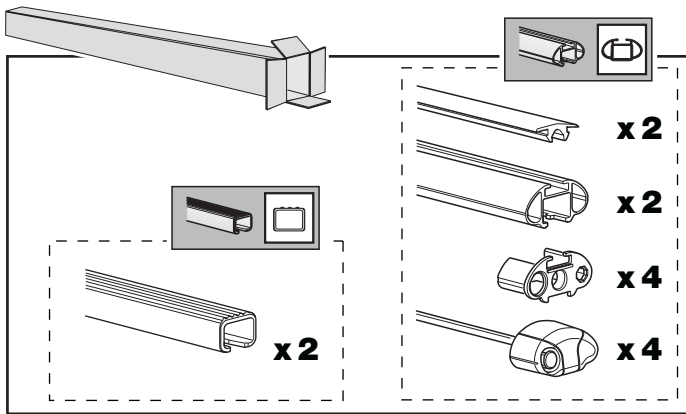
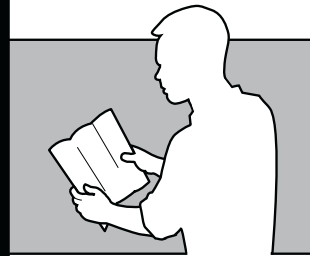
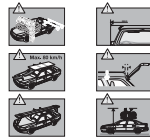

2

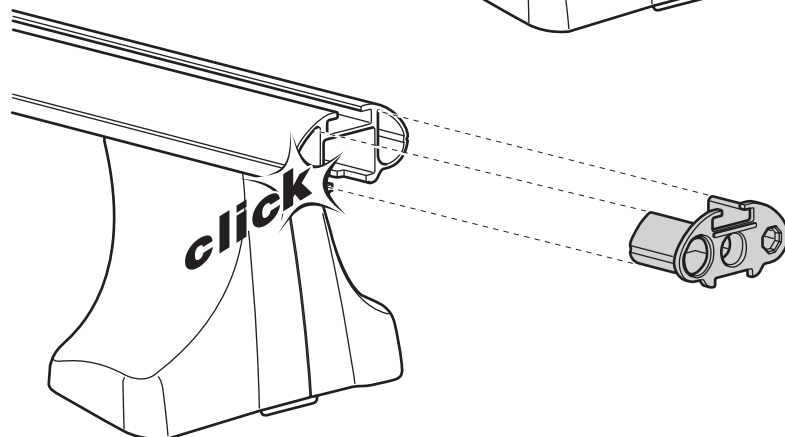
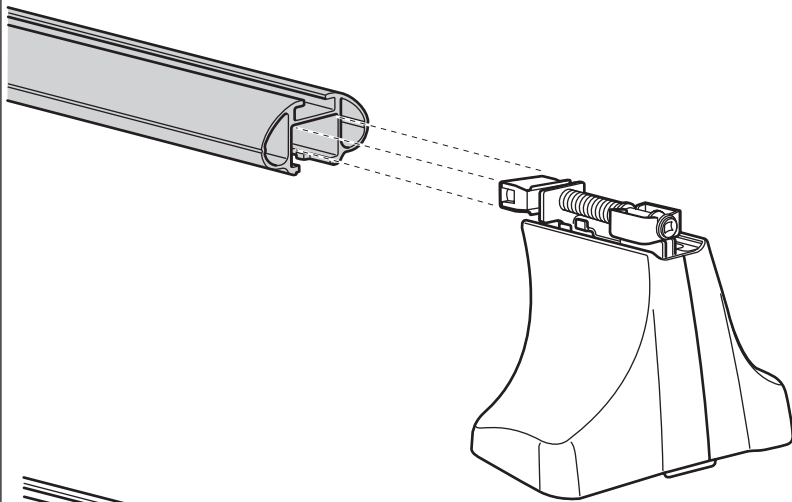
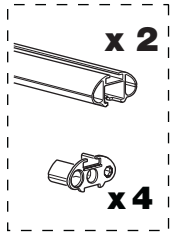
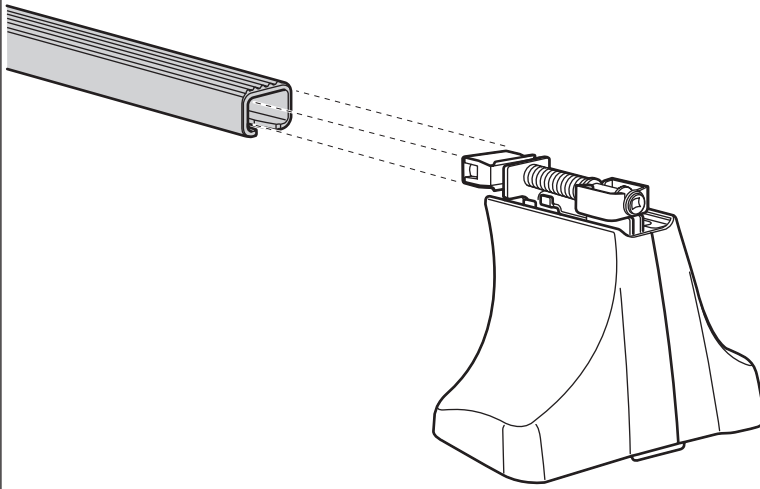
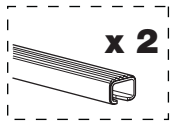
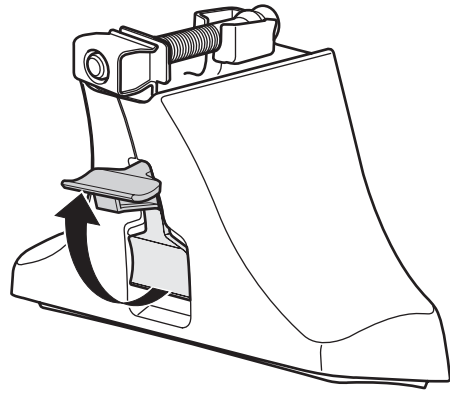
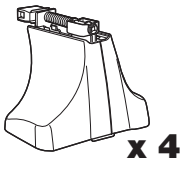

3

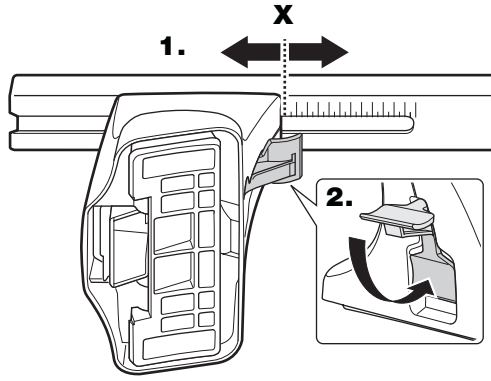
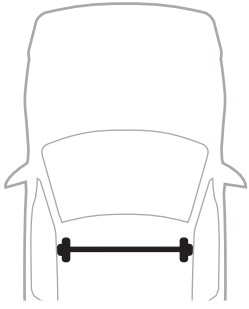

MERCEDES CLC, 2-dr Coupé, 08-

X

31,5

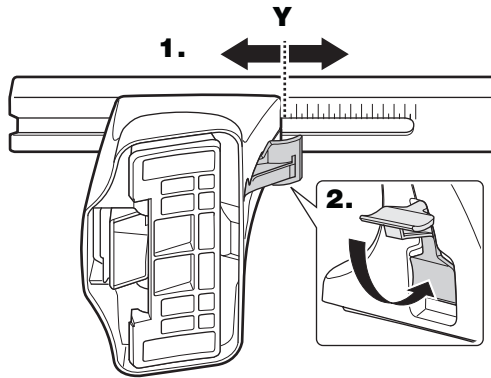
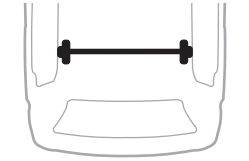

MERCEDES CLC, 2-dr Coupé, 08-

Y

29,5

4

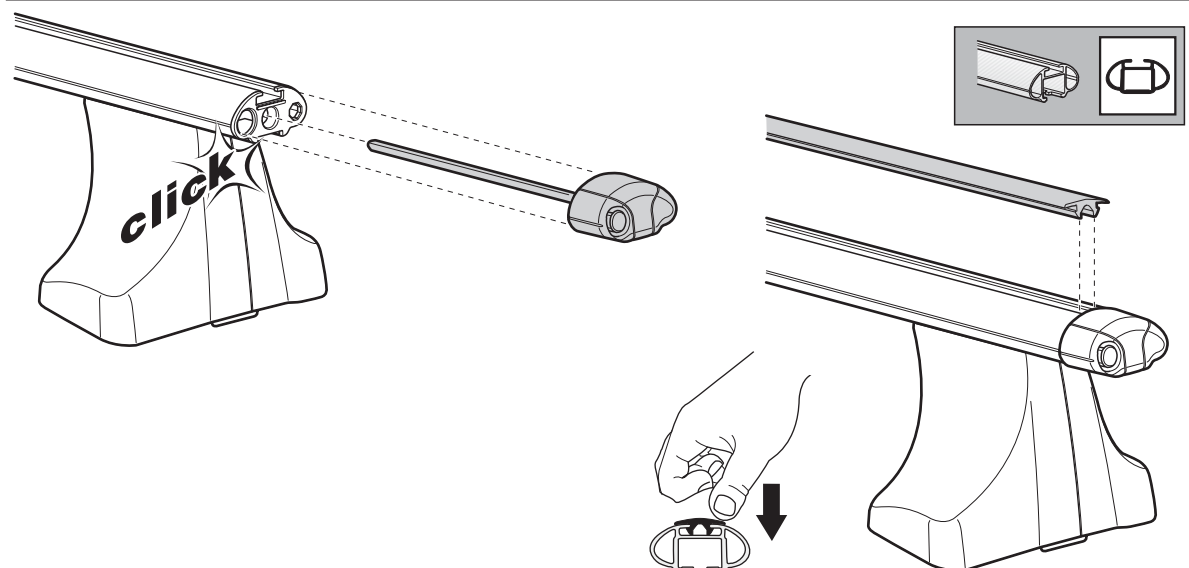
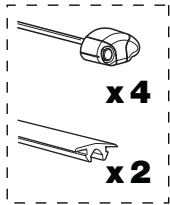
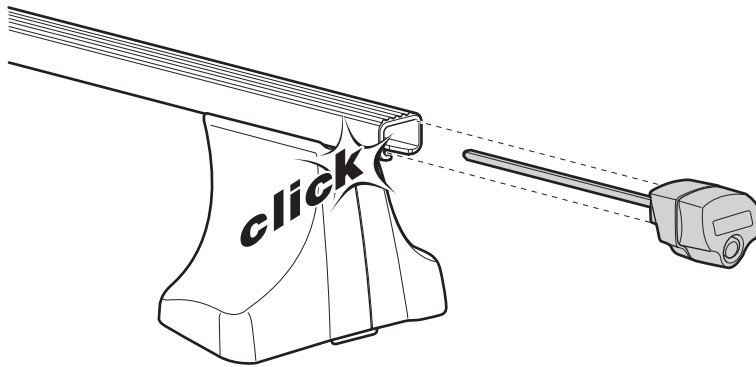
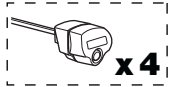

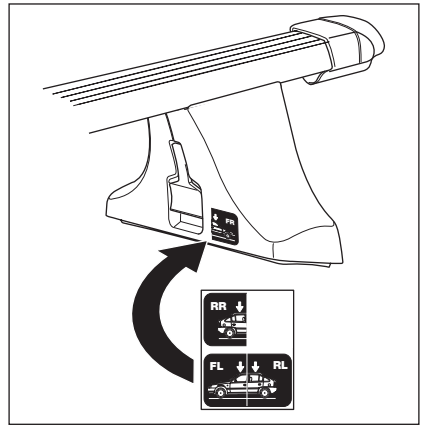
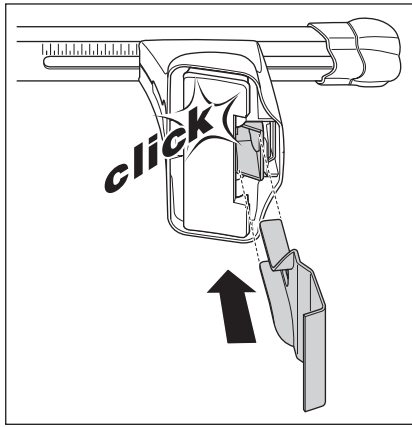
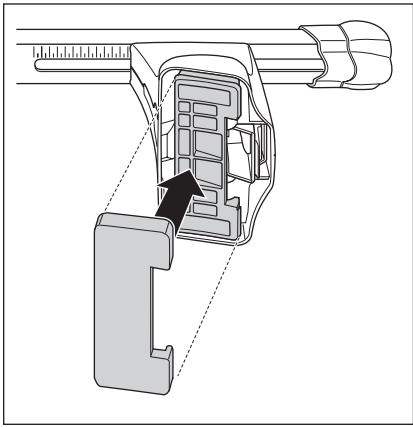

MERCEDES CLC, 2-dr Coupé, 08-

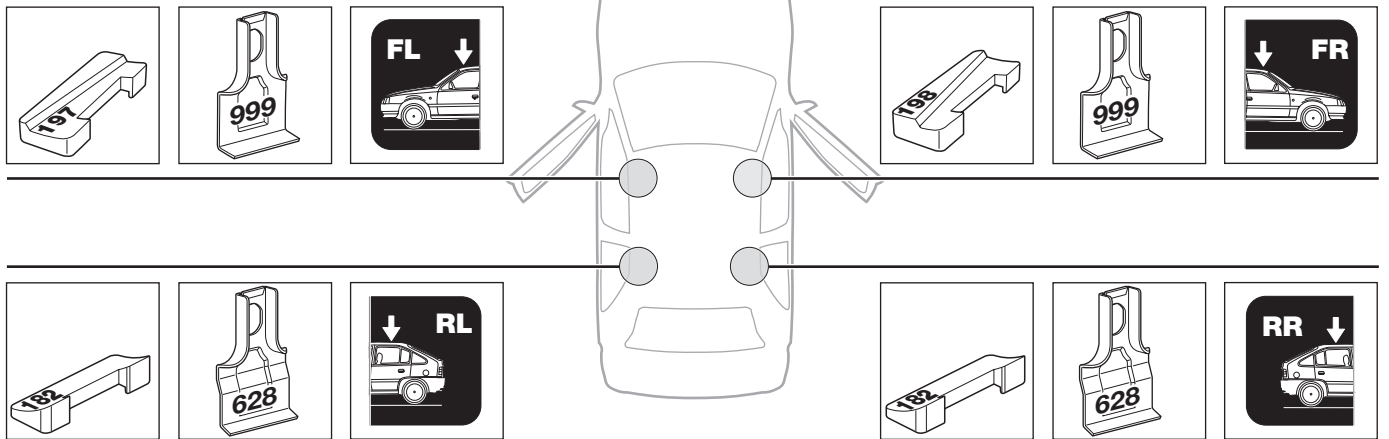

6

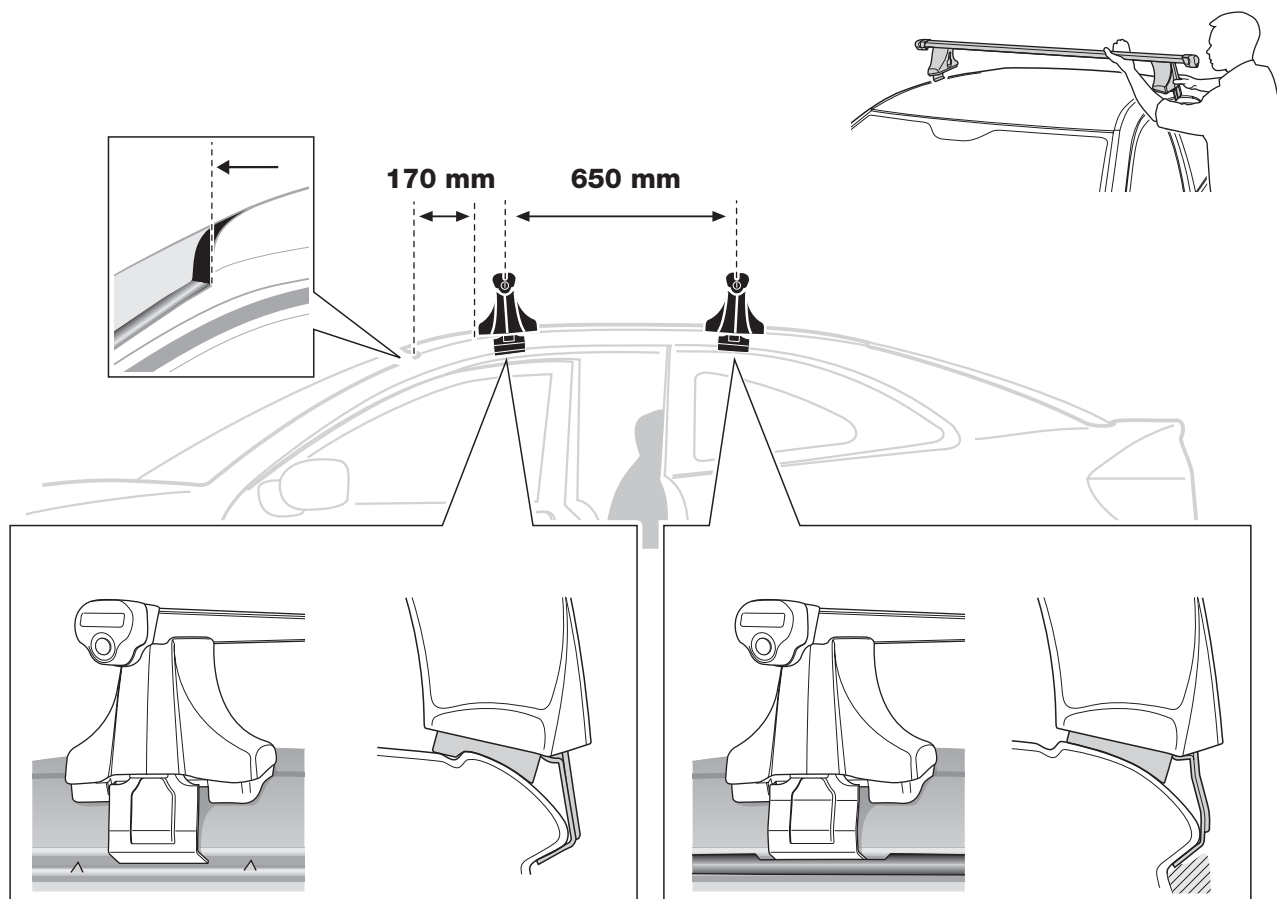

7

- GB** Tighten alternately
- D** Die Schrauben abwechselnd anziehen
- F** Serrer alternativement chaque côté
- NL** Afwisselend aan de linker- en de rechterkant aandraaien
- I** Serrare alternativamente
- E** Alternare il serraggio delle viti
- PT** Aperte alternadamente
- S** Dra åt växelvis
- FIN** Kierrä vuorotellen
- EST** Pinguldage vaheldumisi
- LAT** Pievelciet pamišus
- LIT** Užsukinėkite pakaitomis

- PL** Śruby dokręcaj naprzemiennie
- RU** Затягивайте попеременно
- CZ** Pokręťta багаžníka dokręcaj dokręcaj naprzemiennie.
- SK** Doťahujte striedavo
- SLO** Privijajte izmenično.
- HR** Naizmjenično zategnite
- HU** Egymástól függetlenül szorítandó
- GR** Σφίγγετε εναλλάξ
- TR** Dönüşümlü sıkın
- 中文** 交替拧紧
- 한국어** 번갈아 가며 조이십시오.
- 日本語** 交互に締め付けてください。
- ไทย** ขันในแบบสลับ

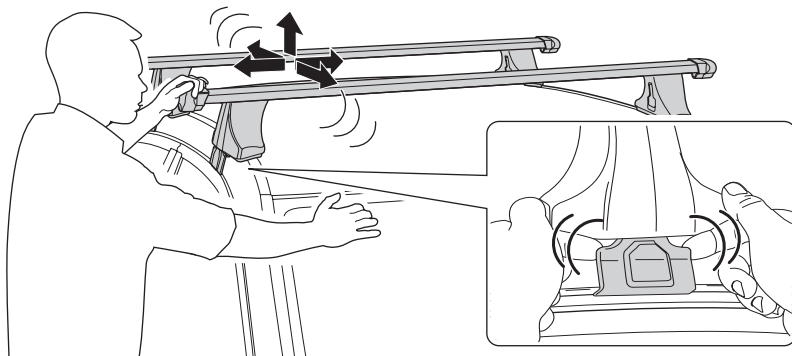
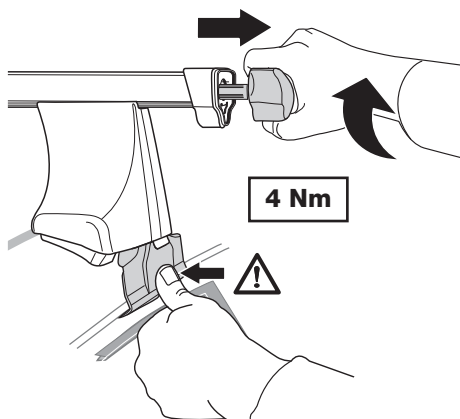
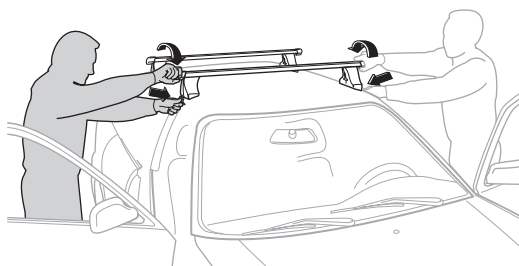

GB Removal
D Demontieren
F Démontage
NL Demontage
I Rimozione

E Desmontaje
PT Remoção
S Demontering
FIN Irrotus
EST Eemaldamine

LAT Noņemšana
LIT Nuėmimas
PL Wymontowywanie
RU СНЯТИЕ
CZ Odmontování

SK Demontáž
SLO Odstranjevanje
HR Uklanjanje
HU Leszerelés
GR Αφαίρεση

TR Sökme
 中文 拆除
 日本語 取り外し
 한국어 분리
 ไทย การถอด

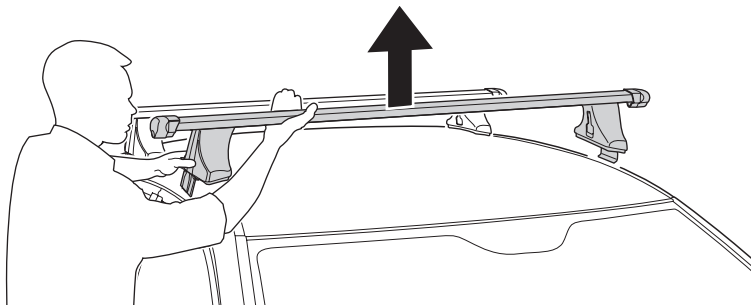
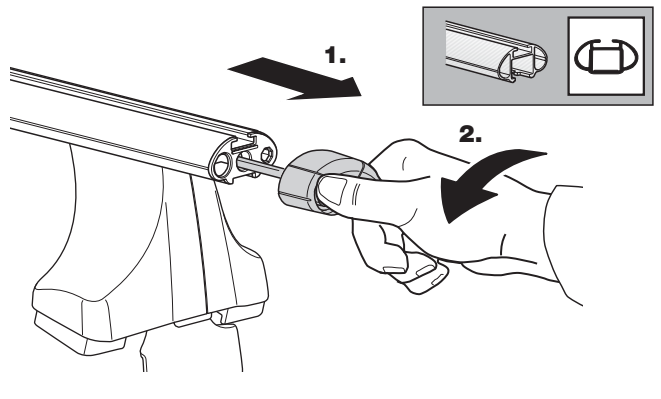
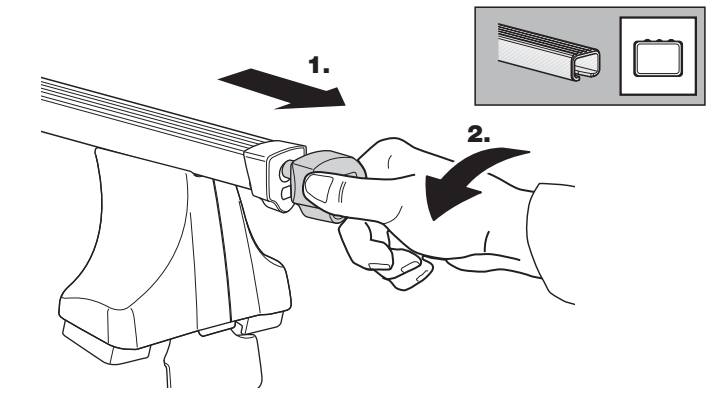

Fit Tips!

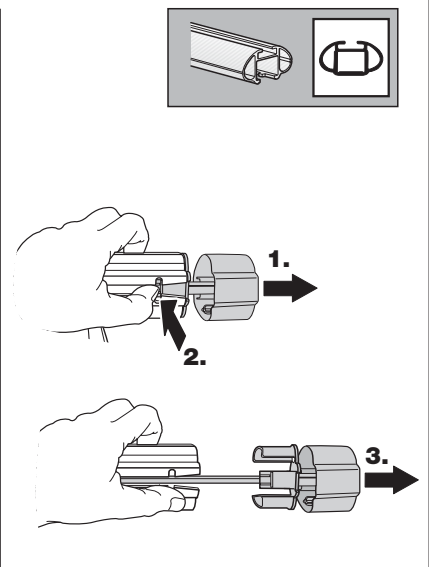
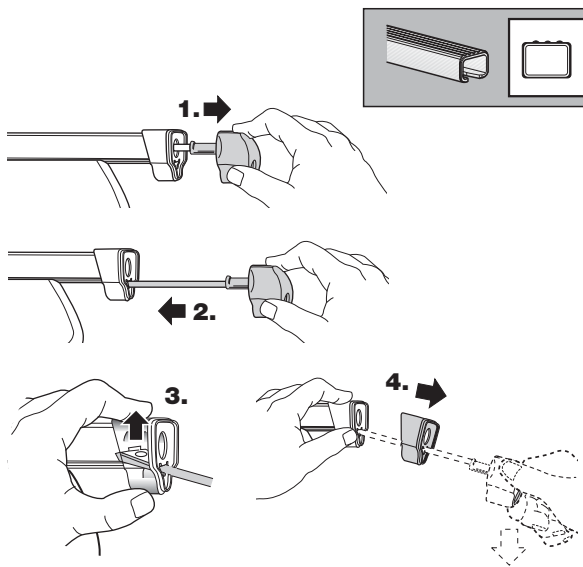
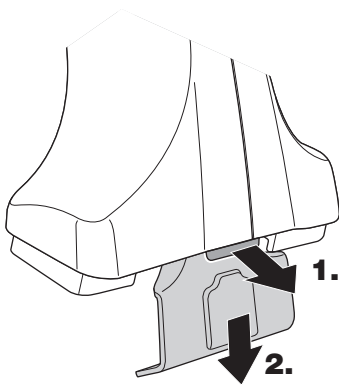

THULE
ONE
KEY
SYSTEM

