

Kit 1657

HYUNDAI Accent, 4-dr Sedan, 11 –

HYUNDAI i25, 4-dr Sedan, 11–

HYUNDAI Solaris, 4-dr Sedan, 11–

HYUNDAI Verna, 4-dr Sedan, 11–

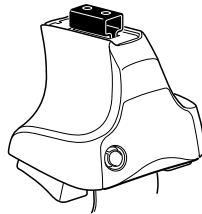

754 Rapid System
480R Rapid Traverse (North America)

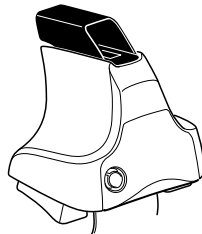
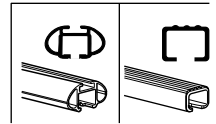

480 Traverse (North America)

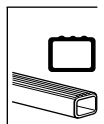

1



2



754 Rapid System
 480R Rapid Traverse
 (North America)

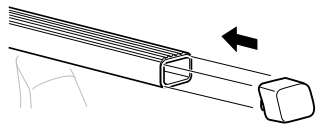
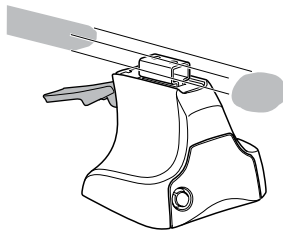

x4

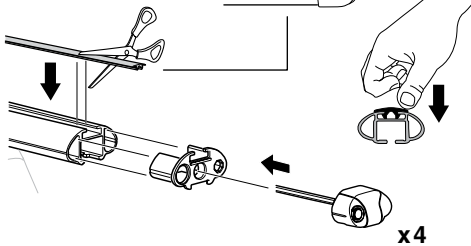
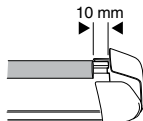
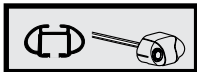

x4

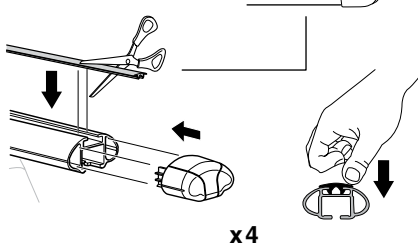
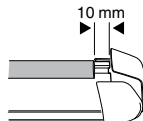
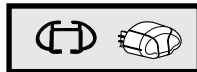

x4



480 Traverse
 (North America)

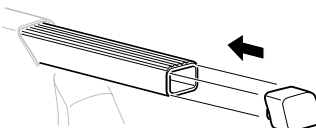
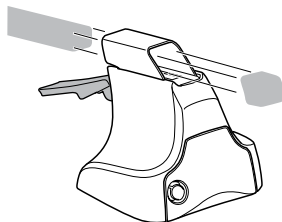

x4

3



754 Rapid System

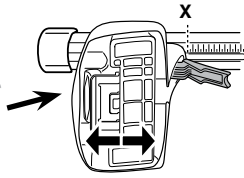

| | X |
|--|-----------|
| HYUNDAI Accent , 4-dr Sedan, 11 – | 36 |
| HYUNDAI i25 , 4-dr Sedan, 11– | 36 |
| HYUNDAI Solaris , 4-dr Sedan, 11– | 36 |
| HYUNDAI Verna , 4-dr Sedan, 11– | 36 |

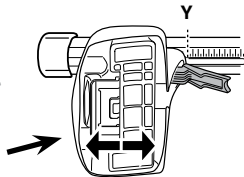

| | Y |
|--|-------------|
| HYUNDAI Accent , 4-dr Sedan, 11 – | 35,5 |
| HYUNDAI i25 , 4-dr Sedan, 11– | 35,5 |
| HYUNDAI Solaris , 4-dr Sedan, 11– | 35,5 |
| HYUNDAI Verna , 4-dr Sedan, 11– | 35,5 |

3



480R Rapid Traverse



480 Traverse

(North America)

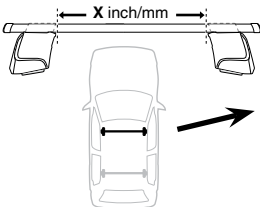

| | X inch | X mm |
|--|--------------------------------------|----------------|
| HYUNDAI Accent , 4-dr Sedan, 11 – | 39 ⁵/₈” | 1011 mm |
| HYUNDAI i25 , 4-dr Sedan, 11– | 39 ⁵/₈” | 1011 mm |
| HYUNDAI Solaris , 4-dr Sedan, 11– | 39 ⁵/₈” | 1011 mm |
| HYUNDAI Verna , 4-dr Sedan, 11– | 39 ⁵/₈” | 1011 mm |

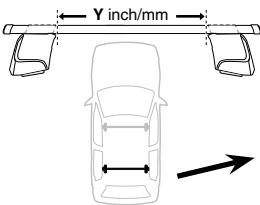

| | Y inch | Y mm |
|--|--------------------------------------|----------------|
| HYUNDAI Accent , 4-dr Sedan, 11 – | 39 ⁵/₈” | 1006 mm |
| HYUNDAI i25 , 4-dr Sedan, 11– | 39 ⁵/₈” | 1006 mm |
| HYUNDAI Solaris , 4-dr Sedan, 11– | 39 ⁵/₈” | 1006 mm |
| HYUNDAI Verna , 4-dr Sedan, 11– | 39 ⁵/₈” | 1006 mm |

4

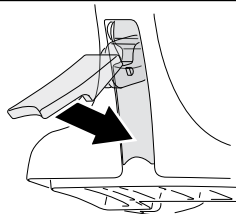

5

HYUNDAI Accent, 4-dr Sedan, 11 -

HYUNDAI i25, 4-dr Sedan, 11 -

HYUNDAI Solaris, 4-dr Sedan, 11 -

HYUNDAI Verna, 4-dr Sedan, 11 -

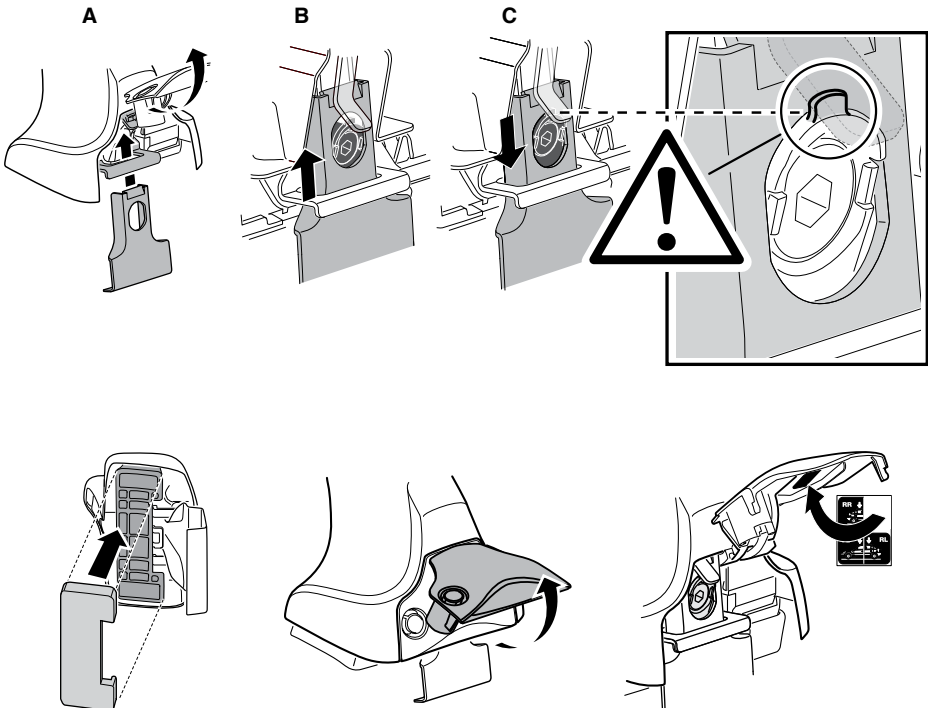
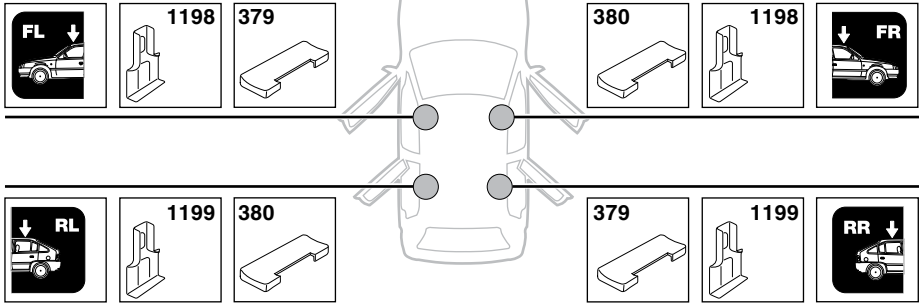

6

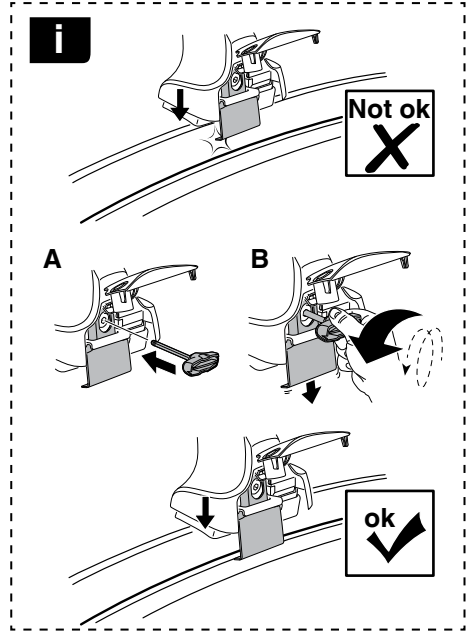
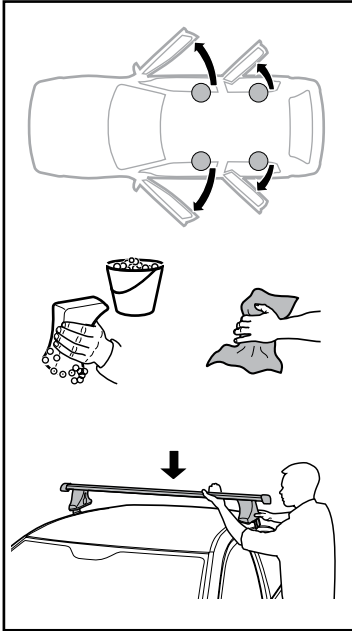

| | X mm | Y mm | X inch | Y inch |
|--|--------|--------|--------|---------|
| HYUNDAI Accent , 4-dr Sedan, 11 – | 185 mm | 690 mm | 7 1/4" | 27 1/8" |
| HYUNDAI i25 , 4-dr Sedan, 11– | 185 mm | 690 mm | 7 1/4" | 27 1/8" |
| HYUNDAI Solaris , 4-dr Sedan, 11– | 185 mm | 690 mm | 7 1/4" | 27 1/8" |
| HYUNDAI Verna , 4-dr Sedan, 11– | 185 mm | 690 mm | 7 1/4" | 27 1/8" |

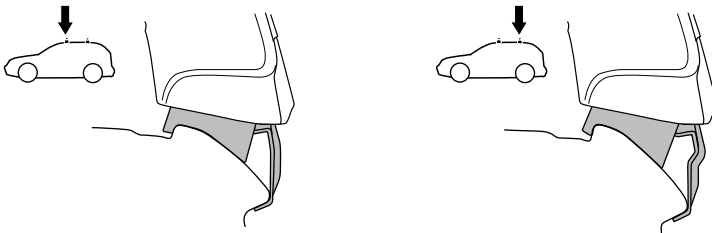
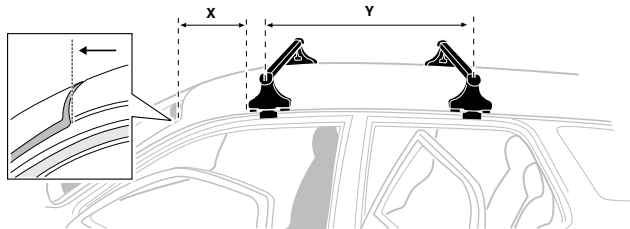

7



| | |
|--------------|---|
| GB/US | Tighten alternately |
| D | Die Schrauben abwechselnd anziehen |
| F | Serrer alternativement chaque côté |
| NL | Afwisselend aan de linker- en de rechterkant aandraaien |
| I | Alternare il serraggio delle viti |
| E | Apertar alternativamente |
| PT | Aperte alternadamente |
| S | Dra åt växelvis |
| FIN | Kierrä vuorotellen |
| EST | Pinguldage vaheldumisi |
| LAT | Pielveiciet pamišus |
| LIT | Užsukinėkite pakaitomis |
| PL | Śruby dokręcaj naprzemiennie |
| RU | Затягивайте попеременно |

| | |
|------------|--|
| CZ | Pokręťta bagażníka dokręcaj naprzemiennie. |
| SK | Dofahujte striedavo |
| SLO | Privijajte izmenično. |
| HR | Naizmjenično zategnite |
| HU | Egymástól függetlenül szorítandó |
| GR | Σφιγίγεται εναλλάξ |
| TR | Dönüşümlü sıkın |

中文 交替拧紧

한국어 번갈아 가며 조이십시오.

日本語 交互に締め付けてください。

ไทย ชันในแบบสลับ

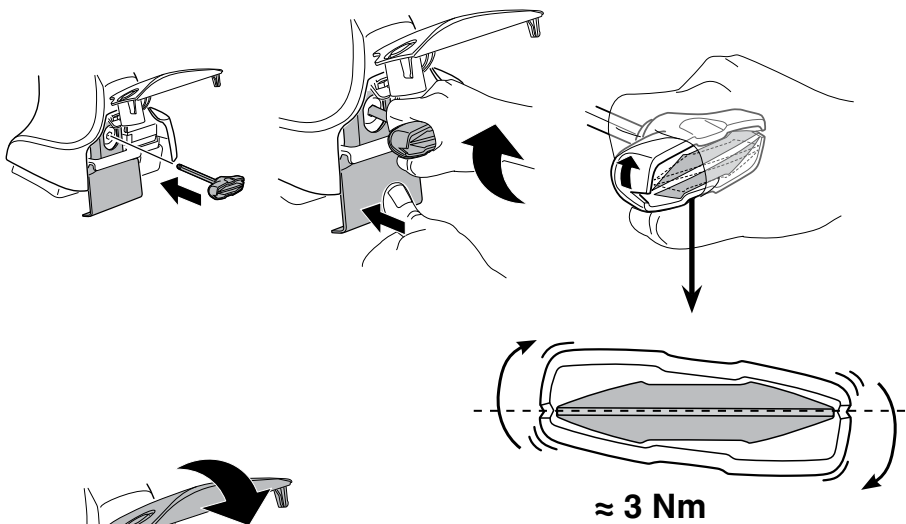

8



x1
17 mm

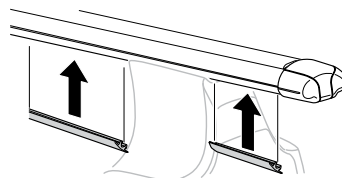
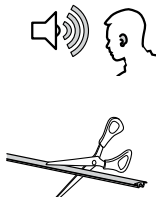

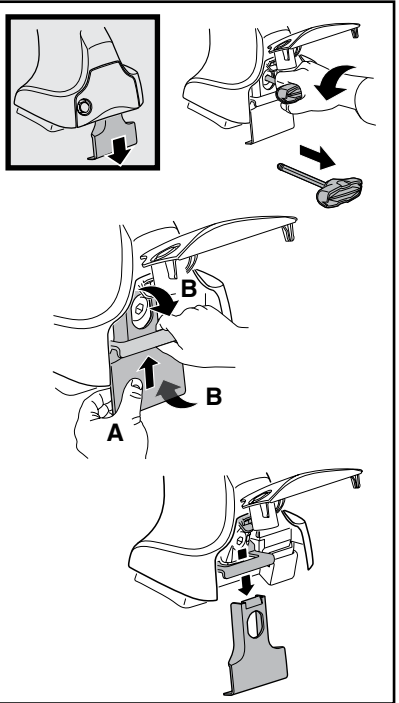
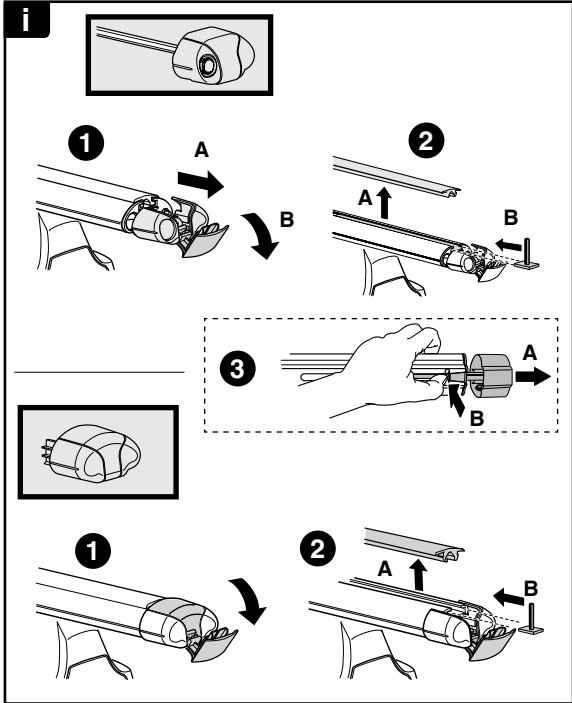

THULE
SWEDEN
**ONE
KEY
SYSTEM**

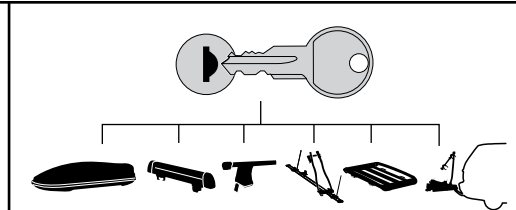

| | | |
|---------|--|-------|
| | | (x4) |
| 544 | | (x6) |
| 596 | | (x8) |
| 588 | | (x10) |
| NA 510 | | (x12) |
| EUR 452 | | |
| ASIA | | |

